

ZONING RESOLUTION Web Version

THE CITY OF NEW YORK



THE CITY OF NEW YORK
Michael R. Bloomberg, Mayor

CITY PLANNING COMMISSION
Amanda M. Burden, Director

Article IV: Manufacturing District Regulations Chapter 3 - Bulk Regulations

Effective date of most recently amended section of Article IV Chapter 3: 04/22/09

Date of file creation: Web version of Article IV Chapter 3: 01/04/10

CITY PLANNING COMMISSION
nyc.gov/planning

DEPARTMENT OF CITY PLANNING
©Copyright 2010 NYC Department of City Planning



12/15/61

**Chapter 3
Bulk Regulations**

12/15/61

**43-00
APPLICABILITY AND GENERAL PROVISIONS**

9/10/07

**43-01
Applicability of this Chapter**

The #bulk# regulations of this Chapter apply to any #building or other structure# on any #zoning lot# or portion of a #zoning lot# located in any #Manufacturing District#, including all new #developments# or #enlargements#. In addition, the #bulk# regulations of this Chapter or of specified Sections thereof also apply in other provisions of this Resolution where they are incorporated by cross reference.

Existing #buildings or other structures# which do not comply with one or more of the applicable #bulk# regulations are #non-complying buildings or other structures# and are subject to the regulations set forth in Article V, Chapter 4.

Special regulations applying to #large-scale community facility developments# are set forth in Article VII, Chapter 8.

Special regulations applying only in Special Purpose Districts are set forth in Article VIII, IX, X, XI, and XII.

In Manhattan Community Districts 1, 2, 3, 4, 5 and 6, Brooklyn Community Districts 1, 2, 6 and 8, and Queens Community Districts 1 and 2, the conversion to #dwelling units# of non-#residential buildings#, or portions thereof, erected prior to December 15, 1961 shall be subject to the provisions of Article I, Chapter 5 (Residential Conversion of Existing Non-Residential Buildings), unless such conversions meet the requirements for new #residential development# of Article II (Residence District Regulations).

In M1-1D, M1-2D, M1-3D, M1-4D and M1-5D Districts, the #bulk#

regulations governing M1 Districts shall apply to #community facility#, #commercial#, and #manufacturing uses#, and the regulations of Section 43-61 (Bulk Regulations for Residential Uses in M1-D Districts) shall apply to #residential uses# authorized pursuant to Section 42-47 (Residential Uses in M1-D Districts).

In the M1-1 District bounded by 95th Avenue, 148th Street, 97th Avenue and 147th Place in Community District 12 in the Borough of Queens, the #bulk# regulations of an M1 District shall apply to #manufacturing#, #commercial# and #community facility uses#, and the #bulk# regulations for an R5 District set forth in Article II, Chapter 3, shall apply to #residential uses#.

Special regulations applying in the #waterfront area# are set forth in Article VI, Chapter 2.

4/30/08

43-02

Street Tree Planting in Manufacturing Districts

M1 M2 M3

In all districts, as indicated, all #developments# or #enlargements# of 20 percent or more in #floor area#, excluding #developments# or #enlargements# in Use Groups 17 or 18, shall provide #street# trees in accordance with Section 26-41 (Street Tree Planting). In addition, any #building# where 20 percent or more of the #floor area# is converted from a #manufacturing use# to a #commercial# or #community facility use# shall provide #street# trees in accordance with Section 26-41. The #street# frontage used to calculate the number of required trees may exclude the #street# frontage occupied by curb cuts serving #uses# listed in Use Groups 16B, C and D.

12/15/61

43-10

FLOOR AREA REGULATIONS

8/18/77

43-11

Definitions

Words in italics are defined in Section 12-10 (DEFINITIONS) or, if applicable exclusively to this Section, in this Section.

10/7/08

43-12

Maximum Floor Area Ratio

M1 M2 M3

In all districts, as indicated, for any #building# on any #zoning lot#, the maximum #floor area ratio# shall not exceed the #floor area ratio# set forth in the following table, except as otherwise provided in the following Sections:

- Section 43-121 (Expansion of existing manufacturing buildings)
- Section 43-122 (Maximum floor area ratio for community facility buildings)
- Section 43-13 (Floor Area Bonus for Public Plazas)
- Section 43-14 (Floor Area Bonus for Arcades)
- Section 43-15 (Existing Public Amenities for which Floor Area Bonuses Have Been Received)
- Section 43-16 (Special Provisions for Zoning Lots Divided by District Boundaries)
- Section 43-61 (Bulk Regulations for Residential Uses in M1-D Districts)

Any given #lot area# shall be counted only once in determining the #floor area ratio#.

Maximum Permitted #Floor Area Ratio#	Districts
1.00	M1-1
2.00	M1-2* M1-4 M2-1 M2-3 M3
5.00	M1-3 M1-5 M2-2 M2-4
10.00	M1-6

- * In Community District 1, in the Borough of Queens, in the M1-2 District bounded by a line 100 feet southwesterly of 37th Avenue, a line 100 feet southeasterly of 24th Street, a line 100 feet southwesterly of 39th Avenue, 24th Street, and a line 100 feet northeasterly of 40th Avenue, 23rd Street, 39th Avenue and 24th Street, the maximum #floor area ratio# shall be increased to 4.0 provided that such additional #floor area# is limited to the following #uses#: photographic or motion picture production studios and radio or television studios listed in Use Group 10A; and #uses# listed in Use Groups 16A, 16D, 17A and 17B as set forth in Section 123-22 (Modification of Use Groups 16, 17 and 18), except for automobile, motorcycle, trailer or boat sales, motorcycle or motor scooter rental establishments, poultry or rabbit killing establishments, riding academies, stables for horses and trade schools for adults.

In #buildings# used partly for #community facility use# and partly for #manufacturing# or #commercial use#, the total #floor area# used for #manufacturing# or #commercial use# shall not exceed the amount permitted in the preceding table or by the bonus provisions in Sections 43-13 or 43-14.

Notwithstanding any other provisions of this Resolution, the maximum #floor area ratio# in an M1-6 District shall not exceed 12.0.

9/9/04

43-121

Expansion of existing manufacturing buildings

M1 M2 M3

In all districts, as indicated, where a #building or other structure# used for a conforming #manufacturing use# was in existence prior to December 15, 1961, such #building or other structure# may be expanded. Such expansion may consist of an #enlargement#, or additional #development#, of not more than 50 percent of the #floor area# existing on December 15, 1961, or an amount resulting in a total #floor area# of not more than 10 percent above the maximum #floor area# otherwise permitted under the provisions of Section 43-12 (Maximum Floor Area Ratio), whichever is the greater amount. However, the resulting #floor

area# shall be limited to 1.5 times the maximum #floor area# otherwise permitted under the provisions of Section 43-12 or 10 percent more than the #floor area# existing prior to December 15, 1961, or a maximum #floor area# limited to 2.4 times the #lot area#, whichever is greater, provided that in the event the 2.4 FAR option is required, the City Planning Commission shall administratively certify and the City Council approve, that the expansion will not adversely affect the surrounding area.

The parking reduction provisions of Section 44-27 (Special Provisions for Expansion of Existing Manufacturing Buildings) shall apply to such expansion.

12/21/89

43-122

Maximum floor area ratio for community facility buildings

M1

In the districts indicated, for any #community facility building# or for any #building# used partly for #community facility uses#, the maximum #floor area ratio# shall not exceed the #floor area ratio# set forth in the following table:

Maximum Permitted #Floor Area Ratio#	Districts
2.40	M1-1
4.80	M1-2
6.50	M1-3 M1-4 M1-5
10.00	M1-6

In M1-1D, M1-2D, M1-3D, M1-4D and M1-5D Districts, for any #building# used partly for #residential use# and partly for #community facility use#, the total #floor area# used for #residential use# shall not exceed the amount permitted in Section 43-61 (Bulk Regulations for Residential Uses in M1-D Districts).

10/17/07

43-13

Floor Area Bonus for Public Plazas

M1-6

In the district indicated, for each square foot of #public plaza# provided on a #zoning lot#, in accordance with the provisions of Section 37-70, inclusive, the total #floor area# permitted on that #zoning lot# under the provisions of Section 43-12 (Maximum Floor Area Ratio) may be increased by six square feet.

6/12/95

43-14

Floor Area Bonus for Arcades

M1-6

In the district indicated, for each square foot of #arcade# provided on a #zoning lot#, the total #floor area# permitted on the #zoning lot# under the provisions of Section 43-12 (Maximum Floor Area Ratio) may be increased by three square feet.

10/17/07

43-15

Existing Public Amenities for which Floor Area Bonuses Have Been Received

- (a) Elimination or reduction in size of non-bonused open area on a #zoning lot# containing a bonused amenity

In all districts, any existing open area for which a #floor area# bonus has not been utilized that occupies the same #zoning lot# as an existing #publicly accessible open area# or other public amenity, open or enclosed, for which a #floor area# bonus has been utilized, may be reduced in size or eliminated only upon certification of the Chairperson of the City Planning Commission that all bonused amenities comply with the standards under which such #floor area# bonus was granted.

- (b) Kiosks and open air cafes

Kiosks and open air cafes may be placed within an existing #publicly accessible open area# for which a #floor area# bonus has been received, by certification, pursuant to

Section 37-73 (Kiosks and Open Air Cafes).

- (c) Nighttime closing of existing #publicly accessible open areas#.

The Commission may, upon application, authorize the closing of an existing #publicly accessible open area# for which a #floor area# bonus has been received, during certain nighttime hours pursuant to Section 37-727 (Hours of access).

- (d) Elimination or reduction of existing public amenities

No existing #arcade#, #publicly accessible open area# or other public amenity, open or enclosed, for which a #floor area# bonus has been utilized, shall be eliminated or reduced in size except by special permit, pursuant to Section 74-761 (Elimination or reduction in size of bonused public amenities).

Regulations Applying in Special Situations

12/15/61

43-16

Special Provisions for Zoning Lots Divided by District Boundaries

M1 M2 M3

In all districts, as indicated, whenever a #zoning lot# is divided by a boundary between districts with different maximum #floor area ratios#, the provisions set forth in Article VII, Chapter 7 shall apply.

1/22/98

43-17

Special Provisions for Joint Living-Work Quarters for Artists in M1-5A and M1-5B Districts

M1-5A M1-5B

In the districts indicated, no #building# containing #joint living-work quarters for artists# shall be #enlarged#.

Mezzanines are allowed within individual quarters, in #buildings# with an existing #floor area ratio# of 12 or less, and only between floors, or between a floor and a roof, existing on January 22, 1998, that are to remain, provided that such mezzanines do not exceed 33 and 1/3 percent of the gross #floor area# of such individual quarters. Such mezzanines shall not be included as #floor area# for the purpose of calculating minimum required size of a #joint living-work quarters for artists#.

In the districts indicated no #building# containing #joint living-work quarters for artists# shall be subdivided into quarters of less than 1,200 square feet except where no #story# contains more than one #joint living-work quarters for artists# unless modified pursuant to Section 43-171.

However, the minimum size requirement may be replaced by the requirements of Section 15-026 for #joint living-work quarters for artists#:

- (a) for which a determination of #residential# or #joint living-work quarters for artists# occupancy on September 1, 1980, has been made pursuant to Sections 42-14, paragraph D.(1)(f), 42-141 paragraph (b) or 74-782; or
- (b) that are registered Interim Multiple Dwellings or are found covered by the New York City Loft Board pursuant to Article 7C of the New York State Multiple Dwelling Law; or
- (c) that the Loft Board determines were occupied for #residential use# or as #joint living-work quarters for artists# on September 1, 1980.

#Joint living-work quarters for artists# existing on September 1, 1980, may not be divided subsequently into quarters of less than 1,200 square feet, unless required by the Loft Board for the legalization of Interim Multiple Dwelling Units in the implementation of Article 7C of the New York State Multiple Dwelling Law.

In the districts indicated, two or more #buildings# which are separated by individual load bearing walls and contain #joint living-work quarters for artists#, each of which #building# conforms to the regulations set forth in Section 42-14 may be combined to produce a #lot area# covered by #buildings# in excess of 3,600 square feet.

43-171**Minor modifications**

On application, the Chairperson of the City Planning Commission may grant minor modifications to the requirements of Section 43-17 relating to #joint living-work quarters for artists# size, provided that the Chairperson of the City Planning Commission had administratively certified to the Department of Buildings that the division of one or more #stories# into #joint living-work quarters for artists# with an area of at least 1,200 square feet cannot be accomplished without practical difficulties because the #floor area# of such #story#, exclusive of exterior walls and common areas, is within five percent of a multiple of 1,200 square feet.

A developer must send a copy of any request for a modification pursuant to this Section to the applicable Community Board at least twenty days prior to the next regularly scheduled Community Board meeting.

1/28/71

43-20**YARD REGULATIONS****Definitions and General Provisions**

11/19/87

43-21**Definitions**

Words in italics are defined in Section 12-10 or, if applicable exclusively to this Section, in this Section.

12/15/61

43-22**Level of Yards**

In all #Manufacturing Districts#, the level of a #yard# or of a #rear yard equivalent# shall not be higher than #curb level#.

However, this Section shall not be construed to require that natural grade level be disturbed in order to comply with this requirement.

No #building or other structure# shall be erected above ground level in any required #yard# or #rear yard equivalent# except as otherwise provided in Section 43-23 (Permitted Obstructions in Required Yards or Rear Yard Equivalents).

4/22/09

43-23

Permitted Obstructions in Required Yards or Rear Yard Equivalents

In all #Manufacturing Districts#, the following shall not be considered obstructions when located within a required #yard# or #rear yard equivalent#:

(a) In any #yard# or #rear yard equivalent#:

Arbors or trellises;

Awnings or canopies;

Chimneys, projecting not more than three feet into, and not exceeding two percent of the area of, the required #yard# or #rear yard equivalent#;

Eaves, gutters or downspouts, projecting into such #yard# or #rear yard equivalent# not more than 16 inches or 20 percent of the width of such #yard# or #rear yard equivalent#, whichever is the lesser distance;

Fences;

Flagpoles;

Parking spaces for automobiles or bicycles, off-street, open, #accessory#;

Steps;

Terraces or porches, open;

Walls, not exceeding eight feet in height and not roofed or part of a #building#;

(b) In any #rear yard# or #rear yard equivalent#:

Any #building# or portion of a #building# used for any permitted #use#, except that any portion of a #building# containing rooms used for living or sleeping purposes (other than a room in a hospital used for the care and treatment of patients, or #joint living-work quarters for artists#) shall not be a permitted obstruction, and provided that the height of such #building# shall not exceed one #story#, excluding #basement#, nor in any event 23 feet above #curb level#;

Breezeways;

Fire escapes;

Parking spaces for automobiles or bicycles, off-street, #accessory#, provided that the height of an #accessory building# used for such purposes and located in a required #rear yard# or #rear yard equivalent# shall not exceed 23 feet above #curb level#;

Water-conserving devices, required in connection with air conditioning or refrigeration systems in #buildings# existing prior to May 20, 1966, if located not less than eight feet from any #lot line#.

However, no portion of a #rear yard equivalent# which is also a required #front yard# or required #side yard# may contain any obstructions not permitted in such #front yard# or #side yard#.

12/15/61

43-24

Measurement of Yard Width or Depth

In all #Manufacturing Districts#, the width or depth of a #yard# or #rear yard equivalent# shall be measured perpendicular to #lot lines#.

Basic Regulations

12/15/61

43-25

Minimum Required Side Yards

M1 M2 M3

In all districts, as indicated, no #side yards# are required. However, if an open area extending along a #side lot line# is provided, it shall be at least eight feet wide.

4/30/08

43-26

Minimum Required Rear Yards

M1 M2 M3

In all districts, as indicated, a #rear yard# with a depth of not less than 20 feet shall be provided at every #rear lot line# on any #zoning lot# except as otherwise provided in Sections 43-27 (Special Provisions for Shallow Interior Lots), 43-28 (Special Provisions for Through Lots) or 43-31 (Other Special Provisions for Rear Yards). #Rear yards# shall also be provided along portions of #side lot lines# as set forth in Section 43-261 (Beyond one hundred feet of a street line).

4/30/08

43-261

Beyond one hundred feet of a street line

M1 M2 M3

In all districts, as indicated, for #corner lots#, and for #zoning lots# that are bounded by two or more #streets# that are neither #corner lots# or #through lots#, the portion of a #side lot line# beyond 100 feet of the #street line# that it intersects shall be considered a #rear lot line# and a #rear yard# with a minimum depth of 20 feet shall be provided where such #rear lot line# coincides with a #rear lot line# of an adjoining #zoning lot#.

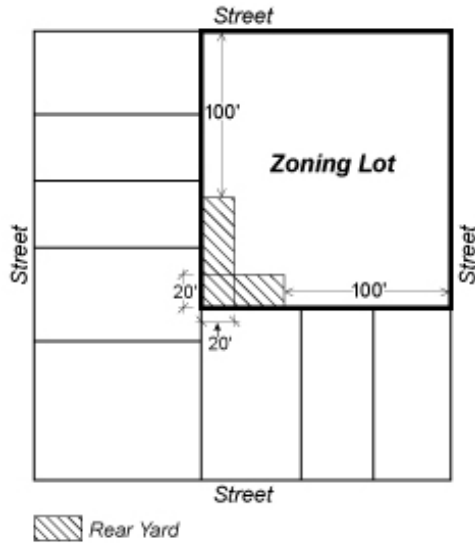

CORNER LOT

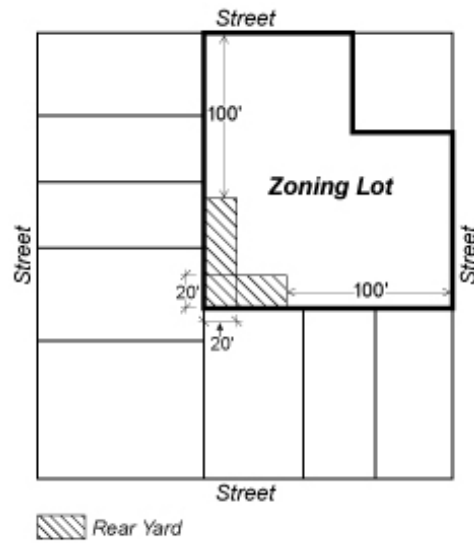

ZONING LOT BOUNDED BY
TWO OR MORE STREETS
(NEITHER A CORNER LOT NOR A THROUGH LOT)

12/15/61

43-27

Special Provisions for Shallow Interior Lots

M1 M2 M3

In all districts, as indicated, if an #interior lot# consists entirely of a tract of land that:

- (a) was owned separately and individually from all other adjoining tracts of land, both on December 15, 1961 and on the date of application for a building permit; and
- (b) is less than 70 feet deep,

the depth of a required #rear yard# for such #interior lot# may be reduced by one foot for each two feet by which the maximum depth of a #zoning lot# is less than 70 feet. No #rear yard# is required on any #interior lot# with a maximum depth of less than 50 feet.

4/30/08

43-28

Special Provisions for Through Lots

M1 M2 M3

In all districts, as indicated, no #rear yard# regulations shall apply to a #building# on any #through lot# which extends less than 110 feet in maximum #lot depth# from #street# to #street#. However, on any #through lot# 110 feet or more in maximum depth from #street# to #street#, one of the following #rear yard equivalents# shall be provided, except that in the case of a #zoning lot# occupying an entire #block#, no #rear yard# or #rear yard equivalent# shall be required:

- (a) an open area with a minimum #lot depth# of 40 feet midway (or within five feet of being midway) between the two #street lines# upon which such #through lot# fronts;
- (b) two open areas, each adjoining and extending along the full length of the #street line#, and each with a minimum depth of 20 feet measured from such #street line#; or
- (c) an open area adjoining and extending along the full length of each #side lot line#, with a minimum width of 20 feet measured from each such #side lot line#.

Any such #rear yard equivalent# shall be unobstructed from its lowest level to the sky, except as provided in Section 43-23 (Permitted Obstructions in Required Yards or Rear Yard Equivalents).

12/15/61

43-29

Special Provisions Applying along Railroad Rights-of-Way

M1 M2 M3

In all districts, as indicated, along such portion of a #rear lot line# which coincides with a boundary of a railroad right-of-way, no #rear yard# shall be required.

12/15/61

43-30

Special Provisions Applying along District Boundaries

M1 M2 M3

In all districts, as indicated, open areas shall be provided in accordance with the provisions of this Section along the boundaries of #Residence Districts# except where such district boundaries are also the boundaries of railroad rights-of-way or cemeteries.

12/15/61

43-301

Required yards along district boundary coincident with side lot line of zoning lot in an R1, R2, R3, R4 or R5 District

M1 M2 M3

In all districts, as indicated, along such portion of the boundary of a #Manufacturing District# which coincides with a #side lot line# of a #zoning lot# in an R1, R2, R3, R4 or R5 District, an open area not higher than #curb level# and at least 15 feet wide shall be provided within the #Manufacturing District#. Such an open area shall not be used for #accessory# off-street parking, #accessory# off-street loading, or for storage or processing of any kind.

12/15/61

43-302

Required yards along district boundary coincident with rear lot lines of the two adjoining zoning lots

M1 M2 M3

In all districts, as indicated, along such portion of the #rear lot line# of a #zoning lot# in a #Manufacturing District# which coincides with a #rear lot line# of a #zoning lot# in an adjoining #Residence District#, an open area not higher than #curb level# and at least 30 feet in depth shall be provided within the #Manufacturing District#. Such an open area shall not be used for storage or processing of any kind.

12/15/61

43-303

Required yards along district boundary coincident with side lot line of zoning lot in a Manufacturing District

M1 M2 M3

In all districts, as indicated, along such portion of a #side lot line# of a #zoning lot# in a #Manufacturing District# which coincides with a #rear lot line# of a #zoning lot# in an adjoining #Residence District#, an open area not higher than #curb level# and at least 15 feet wide shall be provided within the #Manufacturing District#. Such open area shall not be used for #accessory# off-street loading or for storage or processing of any kind.

10/25/67

43-304

Required front yards along district boundary located in a street

M1-1 M1-2 M1-3 M1-4 M2 M3

In the districts indicated, if the boundary of an adjoining #Residence District# is located at the center line of a #street# less than 60 feet wide, a #front yard# not higher than #curb level# and at least 20 feet in depth shall be provided along any #front lot line# forming the boundary between a #zoning lot# located within the #Manufacturing District# and that portion of the #street# in which the district boundary is located.

12/15/61

43-31

Other Special Provisions for Rear Yards

M1 M2 M3

In all districts, as indicated, the #rear yard# requirements set forth in Section 43-26 (Minimum Required Rear Yards) shall be modified as set forth in this Section.

12/15/61

43-311

Within 100 feet of corners

M1 M2 M3

In all districts, as indicated, no #rear yard# shall be required within 100 feet of the point of intersection of two #street lines# intersecting at an angle of 135 degrees or less.

5/20/65

43-312

Along short dimension of block

M1 M2 M3

In all districts, as indicated, whenever a #front lot line# of a #zoning lot# coincides with all or part of a #street line# measuring less than 230 feet in length between two intersecting #streets#, no #rear yard# shall be required within 100 feet of such #front lot line#.

4/30/08

43-313

For zoning lots with multiple rear lot lines

M1 M2 M3

In all districts, as indicated, for #zoning lots# with multiple #rear lot lines#, if a #rear yard# extends from a #rear lot line# away from the #street line# which is used to determine such #rear lot line#, the following rules shall apply:

- (a) A #rear yard# with a minimum depth of 20 feet shall be provided where such #rear lot line# coincides with a #rear lot line# of an adjoining #zoning lot#.

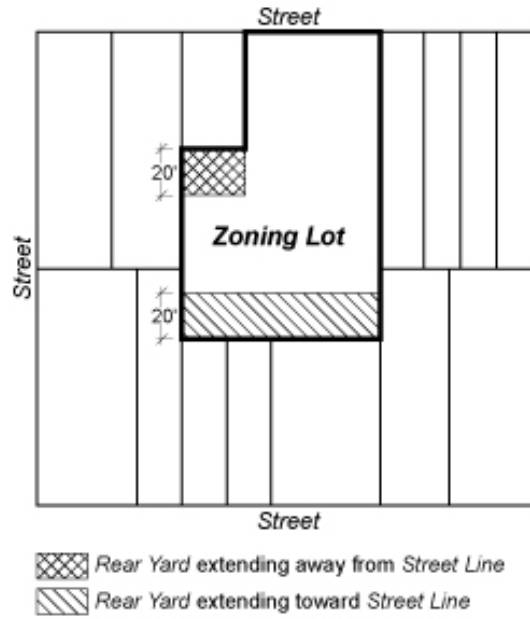

- (b) No rear yard shall be required where such rear lot line coincides with a side lot line of an adjoining zoning lot.

(c) For portions of #through lots# that have multiple #rear lot lines# and such portions are not subject to #interior lot# regulations, the #street line# bounding the #zoning lot# closest to such #rear lot line# shall be used to determine compliance with this Section.

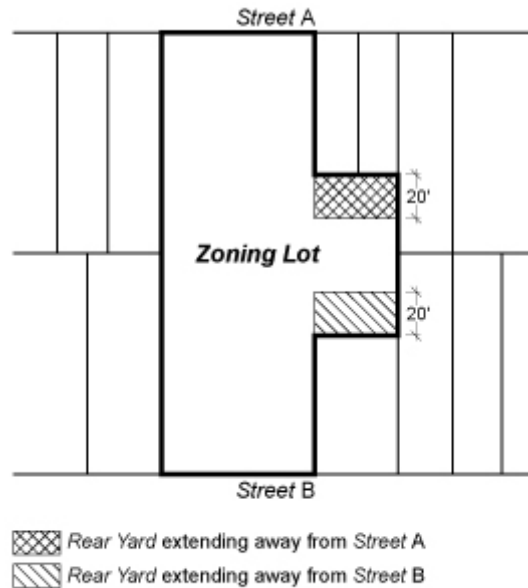

All Yards

12/15/61

43-32

Special Provisions for Zoning Lots Divided by District Boundaries

M1 M2 M3

In all districts, as indicated, whenever a #zoning lot# is divided by a boundary between districts with different #yard# regulations, the provisions set forth in Article VII, Chapter 7, shall apply.

4/30/08

43-33

Modifications of Rear Yard Regulations

M1 M2 M3

In all districts, as indicated, in the regulations set forth in Section 43-313 (For zoning lots with multiple rear lot lines) may be modified in accordance with the provisions of Section 73-69 (Rear Yard Modifications).

12/15/61

**43-40
HEIGHT AND SETBACK REGULATIONS**

Definitions and General Provisions

11/19/87

**43-41
Definitions**

Words in italics are defined in Section 12-10 (DEFINITIONS) or, if applicable exclusively to this Section, in this Section.

9/9/04

**43-42
Permitted Obstructions**

In all #Manufacturing Districts#, the following shall not be considered obstructions and may thus penetrate a maximum height limit or a #sky exposure plane# set forth in Sections 43-43 (Maximum Height of Front Wall and Required Front Setbacks), 43-44 (Alternate Front Setbacks) or 43-49 (Limited Height Districts).

- (a) Chimneys or flues, with a total width not exceeding 10 percent of the #aggregate width of street walls# of a #building# at any given level;
- (b) Elevator or stair bulkheads, roof water tanks or cooling towers (including enclosures), each having an #aggregate width of street walls# equal to not more than 30 feet. However, the product, in square feet, of the #aggregate width of street walls# of such obstructions facing each #street# frontage, times their average height, in feet,

shall not exceed a figure equal to four times the width, in feet, of the #street wall# of the #building# facing such frontage;

- (c) Flagpoles or aerials;
- (d) House of worship towers, ornamental, having no #floor area# in portion of tower penetrating such height limit or #sky exposure plane#;
- (e) Parapet walls, not more than four feet high;
- (f) Spires or belfries;
- (g) Wire, chain link or other transparent fences.

Building columns having an aggregate width equal to not more than 20 percent of the #aggregate width of street walls# of a #building# are a permitted obstruction, to a depth not exceeding 12 inches, in an #initial setback distance#, optional front open area, or any other required setback distance or open area set forth in Sections 43-43, 43-44 or 43-45 (Tower Regulations).

12/15/61

43-43

Maximum Height of Front Wall and Required Front Setbacks

M1 M2 M3

In all districts, as indicated, if the front wall or any other portion of a #building or other structure# is located at the #street line# or within the #initial setback distance# as set forth in the following table, the height of such front wall or other portion of a #building or other structure#, except as otherwise set forth in this Section, shall not exceed the maximum height above #curb level# set forth in the following table. Above such maximum height and beyond the #initial setback distance#, the #building# shall not penetrate the #sky exposure plane# set forth in the following table.

The regulations of this Section shall apply except as otherwise provided in Sections 43-42 (Permitted Obstructions), 43-44 (Alternate Front Setbacks) or 43-45 (Tower Regulations). In M1-1 Districts, for #community facility buildings# the maximum height of a front wall shall be 35 feet or three #stories#, whichever is less, and the height above the #street line# shall be 35 feet, and in M1-4 Districts, for #community facility buildings#, the

maximum height of a front wall shall be 60 feet or six #stories#,
whichever is less.

MAXIMUM HEIGHT OF FRONT WALL
AND REQUIRED FRONT SETBACKS

#Initial Setback Distance# (in feet)		Maximum Height of a Front Wall, or other Portion of a #Building# within the #Initial Setback Distance#	Height above #Street Line# (in feet)	#Sky Exposure Plane#			
				Slope over #Zoning Lot# (expressed as a ratio of vertical distance to horizontal distance)			
On #Narrow Street#	On #Wide Street#			On #Narrow Street#	On #Wide Street#		
				Verti- cal Dis- tance	Hori- zon- tal Dis- tance	Verti- cal Dis- tance	Hori- zon- tal Dis- tance
District: M1-1							
20	15	30 feet or 2 #stories#, whichever is less	30	1 to	1	1 to	1
Districts: M1-2 M1-4 M2-1 M2-3 M3							
20	15	60 feet or 4 #stories#, whichever is less	60	2.7 to	1	5.6 to	1
Districts: M1-3 M1-5 M1-6 M2-2 M2-4							
20	15	85 feet or 6 #stories#, whichever is less	85	2.7 to	1	5.6 to	1

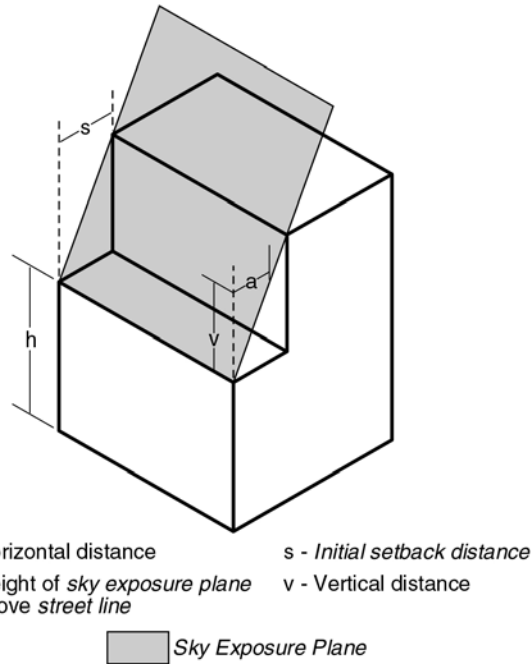

Sky Exposure Plane

10/17/07

**43-44
Alternate Front Setbacks**

M1 M2 M3

In all districts, as indicated, if an open area is provided along the full length of the #front lot line# with the minimum depth set forth in the following table, the provisions of Section 43-43 (Maximum Height of Front Wall and Required Front Setbacks) shall not apply. The minimum depth of such open area shall be measured perpendicular to the #front lot line#. However, in such instances, except as otherwise provided in this Section or in Sections 43-42 (Permitted Obstructions) or 43-45 (Tower Regulations), no #building or other structure# shall penetrate the alternate #sky exposure plane# set forth in the following table. The #sky exposure plane# shall be measured from a point above the #street line#.

In an M1-6 District, if the open area provided under the terms of this Section is a #public plaza#, such open area may be counted toward the bonus provided for a #public plaza#, pursuant to

Section 43-13 (Floor Area Bonus for Public Plazas).

In M1-1 Districts, for #community facility buildings# the height above #street line# shall be 35 feet.

ALTERNATE REQUIRED FRONT SETBACKS

Depth of Optional Front Open Area (in feet)		Height above #Street Line# (in feet)	Alternative #Sky Exposure Plane#			
			Slope over #Zoning Lot# (expressed as a ratio of vertical distance to horizontal distance)			
On #Narrow Street#	On #Wide Street#	Height above #Street Line# (in feet)	On #Narrow Street#	On #Wide Street#	On #Narrow Street#	On #Wide Street#
			Vertical Distance	Hori-zontal Distance	Vertical Distance	Hori-zontal Distance
District: M1-1						
15	10	30	1.4 to	1	1.4 to	1
Districts: M1-2 M1-4 M2-1 M2-3 M3						
15	10	60	3.7 to	1	7.6 to	1
Districts: M1-3 M1-5 M1-6 M2-2 M2-4						
15	10	85	3.7 to	1	7.6 to	1

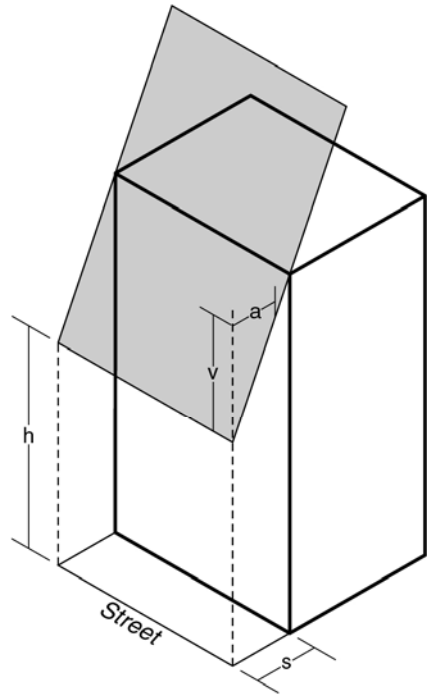

- a - Horizontal distance
 - h - Height of *sky exposure plane* above street line
 - s - Depth of the optional front open area
 - v - Vertical distance
- Sky Exposure Plane*

Alternate Sky Exposure Plane

Supplementary Regulations

4/22/65

43-45 Tower Regulations

M1-3 M1-4 M1-5 M1-6

In the districts indicated, any #building# or #buildings# or portion thereof which in the aggregate occupy not more than 40 percent of the #lot area# of a #zoning lot# or, for #zoning lots# of less than 20,000 square feet, the percent set forth in Section 43-451 (Towers on small lots), may penetrate an established #sky exposure plane#. (Such #building# or portion thereof is

hereinafter referred to as a tower.) At any given level, such tower may occupy any portion of the #zoning lot# not located less than 15 feet from the #street line# of a #narrow street#, or less than 10 feet from the #street line# of a #wide street#, provided that the aggregate area so occupied within 50 feet of a #narrow street# shall not exceed 1,875 square feet and the aggregate area so occupied within 40 feet of a #wide street# shall not exceed 1,600 square feet.

If the #building# of which such tower is a portion does not occupy at any level more than the maximum percent of the #lot area# set forth in this Section or Section 43-451 for towers, the tower may occupy any portion of the #zoning lot# not located less than 20 feet from the #street line# of a #narrow street# or less than 15 feet from the #street line# of a #wide street#, provided that the aggregate area so occupied within 50 feet of a #narrow street# shall not exceed 2,250 square feet and the aggregate area so occupied within 40 feet of a #wide street# shall not exceed 2,000 square feet.

12/15/61

43-451

Towers on small lots

M1-3 M1-4 M1-5 M1-6

In the districts indicated, a tower may occupy the percent of the #lot area# of a #zoning lot# set forth in the following table:

LOT COVERAGE OF TOWERS
ON SMALL ZONING LOTS

Area of #Zoning Lot# (in square feet)	Maximum Percent of #Lot Coverage#
10,500 or less	50
10,501 to 11,500	49
11,501 to 12,500	48
12,501 to 13,500	47
13,501 to 14,500	46
14,501 to 15,500	45
15,501 to 16,500	44

16,501 to 17,500	43
17,501 to 18,500	42
18,501 to 19,999	41

Regulations Applying in Special Situations

12/15/61

43-46

Special Provisions for Zoning Lots Directly Adjoining Public Parks

M1 M2 M3

In all districts, as indicated, a #public park# with an area of between one and fifteen acres shall be considered a #wide street# for the purpose of applying the height and setback regulations as set forth in Section 43-43 (Maximum Height of Front Wall and Required Front Setbacks) to any #building or other structure# on a #zoning lot# adjoining such #public park#. However, the provisions of this Section shall not apply to a #public park# more than 75 percent of which is paved.

12/15/61

43-47

Modification of Height and Setback Regulations

M1

In the district indicated, for certain #community facility uses# in specified situations, the Board of Standards and Appeals may modify the regulations set forth in Sections 43-41 to 43-45, inclusive, relating to Height and Setback Regulations, in accordance with the provisions of Section 73-64 (Modifications for Community Facility Uses).

12/15/61

43-48

Special Provisions for Zoning Lots Divided by District Boundaries

M1 M2 M3

In all districts, as indicated, whenever a #zoning lot# is divided by a boundary between districts with different height and setback regulations, or whenever a #zoning lot# is divided by a boundary between a district to which the provisions of Section 43-45 (Tower Regulations) apply and a district to which such provisions do not apply, the provisions set forth in Article VII, Chapter 7 shall apply.

4/4/82

43-49

Limited Height Districts

M1 M2 M3

In all districts, as indicated, wherever such districts are located within a #Limited Height District#, the maximum height of a #building or other structure#, or portion thereof, shall be as shown in the following table:

#Limited Height District#	Maximum Height above #Curb Level#
LH-1	50 feet
LH-1A	60 feet
LH-2	70 feet
LH-3	100 feet

12/15/61

43-50

**COURT REGULATIONS AND MINIMUM DISTANCE BETWEEN WINDOWS AND WALLS
OR LOT LINES**

Basic Regulations

3/8/62

43-51

Minimum Dimensions of Courts for Community Facility Buildings

M1

In the district indicated, the regulations set forth in the following Sections shall apply to all #buildings# containing #community facility uses#:

- Section 24-61 (General Provisions and Applicability)
- Section 24-62 (Minimum Dimensions of Courts)
- Section 24-63 (Outer Court Regulations)
- Section 24-64 (Inner Court Regulations)
- Section 24-65 (Minimum Distance between Required Windows and Walls or Lot Lines)
- Section 24-66 (Modifications of Court Regulations or Distance Requirements)
- Section 24-68 (Permitted Obstructions in Courts).

12/21/89

43-60 SUPPLEMENTARY REGULATIONS

9/9/04

43-61 Bulk Regulations for Residential Uses in M1-D Districts

The following regulations shall apply to any new #building# or #residential enlargement# authorized pursuant to Section 42-47 (Residential Uses in M1-D Districts):

- (a) The total amount of #residential floor area# permitted in any #building# shall not exceed a #floor area ratio# of 1.65.

In #buildings# used partly for #residential use# and partly for #community facility#, #manufacturing# or #commercial use#, the maximum #floor area# shall be the maximum #floor

area# permitted for either the #commercial# or #manufacturing# portion of such #building# as set forth in Sections 43-12 (Maximum Floor Area Ratio) through 43-14 (Floor Area Bonus for Arcades), or the #community facility# portion of such #building# as set forth in Section 43-122 (Maximum floor area ratio for community facility buildings), or the #residential# portion of such #building# as set forth in this Section, whichever permits the greatest amount of #floor area#.

In #buildings# used partly for #residential use# and partly for #manufacturing# or #commercial use#, the total #floor area# used for #manufacturing# or #commercial use# shall not exceed the amount permitted by Sections 43-12 through 43-14.

- (b) The maximum number of #dwelling units# shall equal the total #residential floor area# provided in the #building# divided by 675. Fractions equal to or greater than three quarters resulting from this calculation shall be considered to be one #dwelling unit#.
- (c) The maximum height above #curb level# shall be 32 feet for any new #residential building# or #enlarged# portion.
- (d) No #residential building# or #residential enlargement# shall be permitted within 30 feet of the #rear lot line#.
- (e) The maximum distance from the #street line# to the #street wall# of any new #building developed# pursuant to this Section shall be ten feet, unless modified by the Commission pursuant to Section 44-28 (Parking Regulations for Residential Uses in M1-D Districts).
- (f) No #side yards# shall be required. However, if any open area extending along a #side lot line# is provided at any level it shall have a width of not less than eight feet. However, #enlargements# of #single-family# or #two-family residences# existing as of June 20, 1988, shall be exempt from this requirement, provided such #enlarged building# does not exceed a height of two #stories#.